

CLAMPBRO®

METALWORKER



ADJUSTABLE BENCH GRINDER STAND

Model No: CBGS2

Part No: 6501142

ASSEMBLY INSTRUCTIONS

INTRODUCTION

Thank you for purchasing this CLARKE bench grinder stand. It is designed for general workshop use and will accommodate most bench grinders with 2 or 4 bolt mountings. Its heavy duty, cast iron construction ensures security and stability of the bench grinder, which is assured by anchoring the stand to the floor.

Please read and follow the instructions carefully. In doing so you will ensure the safety of yourself and others around you, and you can look forward to the product giving you long and satisfactory service.

Please keep these instructions in a safe place for future reference

GUARANTEE

This product is guaranteed against faulty manufacture for a period of 12 months from the date of purchase. Please keep your receipt which will be required as proof of purchase.

This guarantee is invalid if the product is found to have been abused or tampered with in any way, or not used for its intended purpose. Faulty goods should be returned to their place of purchase. No product can be returned to us without prior permission.

This guarantee does not effect your statutory rights.

ASSEMBLY

1. Slide the lower column into the base and secure with the two M10 x 10 setscrews.
2. Slide the storage shelf over the lower column, and secure with the two hex head bolts & flat washers. Fit the two wheel storage boxes to the storage shelf using the self-tapping screws.
3. Screw in the tensioning knob and the upper column stop screw with spring washer, into their holes in the lower column.
4. Locate the grinder mounting table onto the upper column, securing with the four socket head screws provided.
5. Screw the cable retaining hook to the table from underneath using the small screw & flat washer
6. Slide the upper column down into the lower column and set in your chosen position by twisting it, so that the stop screw engages into one of the positioning slots. Fasten securely with the tensioning knob.



CAUTION: DO NOT FIT THE BENCH GRINDER TO THE STAND UNTIL THE STAND IS BOLTED TO THE FLOOR. THE STAND IS NOT DESIGNED TO BE FREE-STANDING AND THE BASE MUST BE SECURED TO THE FLOOR PRIOR TO MOUNTING THE GRINDER.

A 12mm hole is provided on the end of each foot to allow the stand to be anchored to the floor. Ensure the floor is level before the stand is secured.

Site the grinder in a well lit area, where you will not be working in your own shadow.

Ensure an adequate electrical supply is close at hand - avoid long extensions which are a hazard in a workshop environment.

The bench grinder should be mounted with its centre of gravity as near to the centre of the table as possible.

Ensure that the correct size bolts (from those provided) are used for the size of holes in your grinder mountings, and that flat washers are used to compensate for the oversize holes in the table.

The nuts should be nipped up firmly, but be careful not to overtighten them.

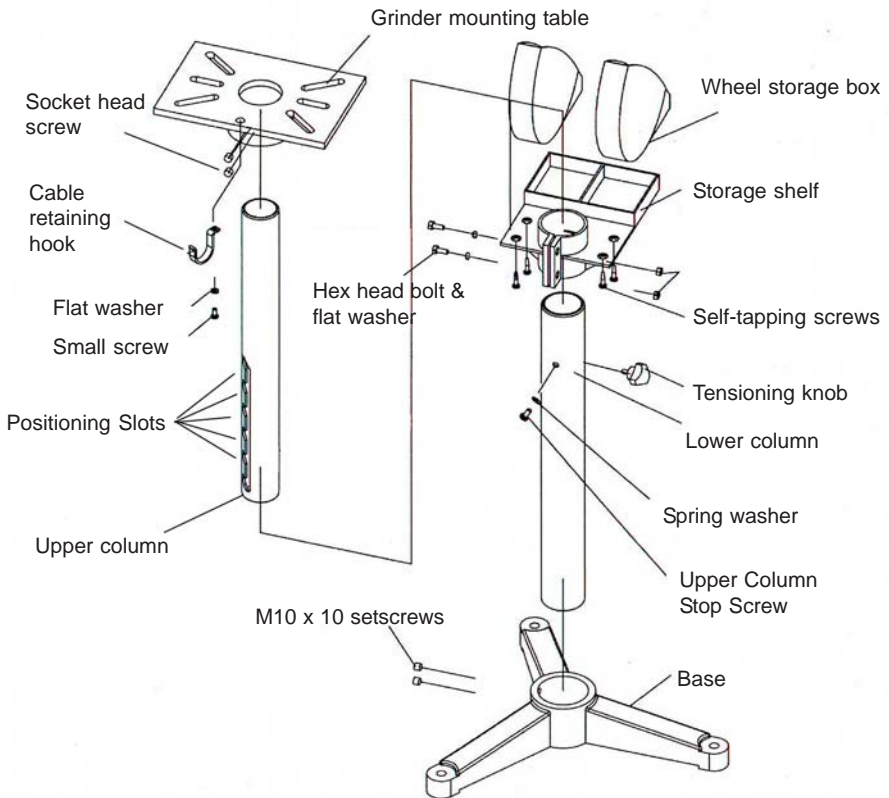

A SELECTION FROM THE VAST RANGE OF

Clarke®

QUALITY PRODUCTS

AIR COMPRESSORS

From DIY to industrial, Plus air tools, spray guns and accessories.

GENERATORS

Prime duty or emergency standby for business, home and leisure.

POWER WASHERS

Hot and cold, electric and engine driven - we have what you need

WELDERS

Mig, Arc, Tig and Spot. From DIY to auto/industrial.

METALWORKING

Drills, grinders and saws for DIY and professional use.

WOODWORKING

Saws, sanders, lathes, mortisers and dust extraction.

HYDRAULICS

Cranes, body repair kits, transmission jacks for all types of workshop use.

WATER PUMPS

Submersible, electric and engine driven for DIY, agriculture and industry.

POWER TOOLS

Angle grinders, cordless drill sets, saws and sanders.

STARTERS/CHARGERS

All sizes for car and commercial use.



PARTS & SERVICE: 020 8988 7400

E-mail: Parts@clarkeinternational.com or Service@clarkeinternational.com

SALES: UK 01992 565333 or Export 00 44 (0)1992 565335

Clarke INTERNATIONAL Hemnall Street, Epping, Essex CM16 4LG
www.clarkeinternational.com